

EXCEPTIONAL HYGIENE



**Hygienic
Wall Protection**

POLYSTO SANICOAT COVERED SKIRTINGS AND KERBS

PROTECTION LEVEL 1 - 4 POLYSTO STAINLESS STEEL SAFETY BOLLARDS



PROTECTION LEVEL 1

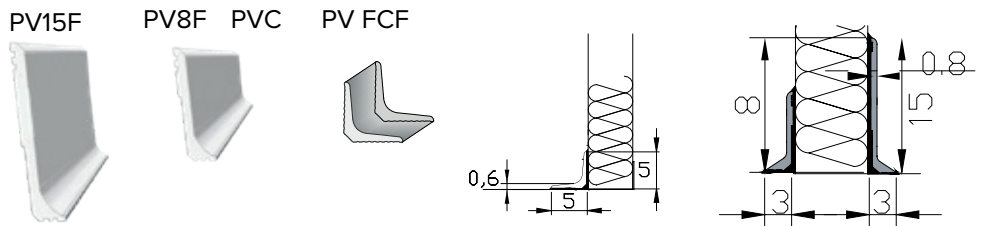

PROTECTION LEVEL 2

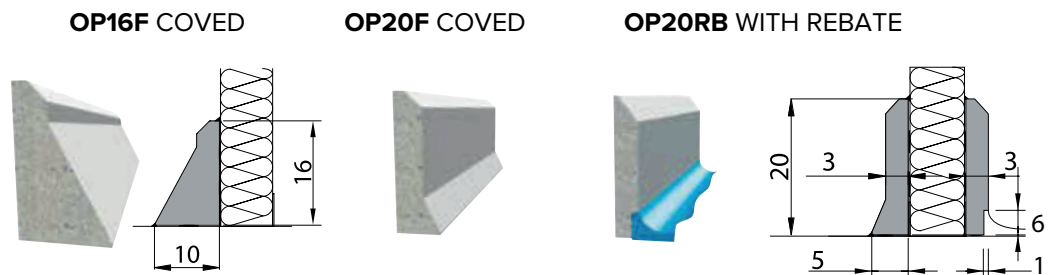

PROTECTION LEVEL 3

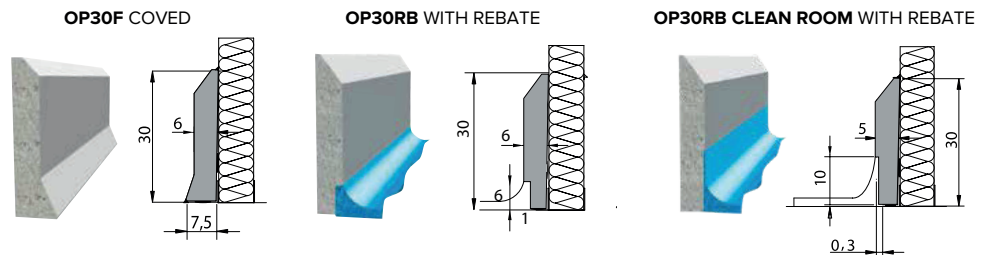

PROTECTION LEVEL 4

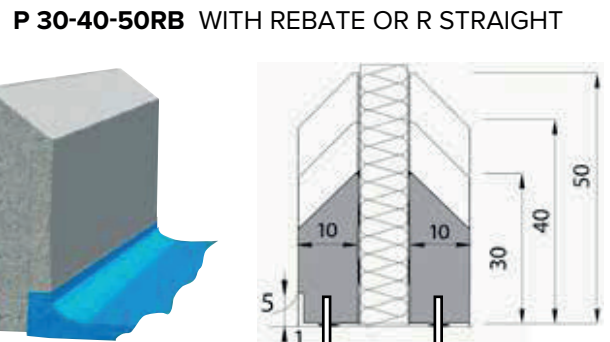
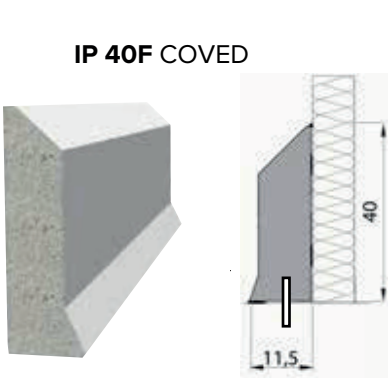
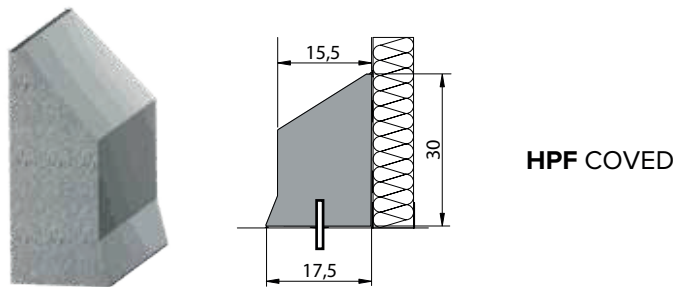

POLYSTO POLYETHYLENE WALL PROTECTION - PE500

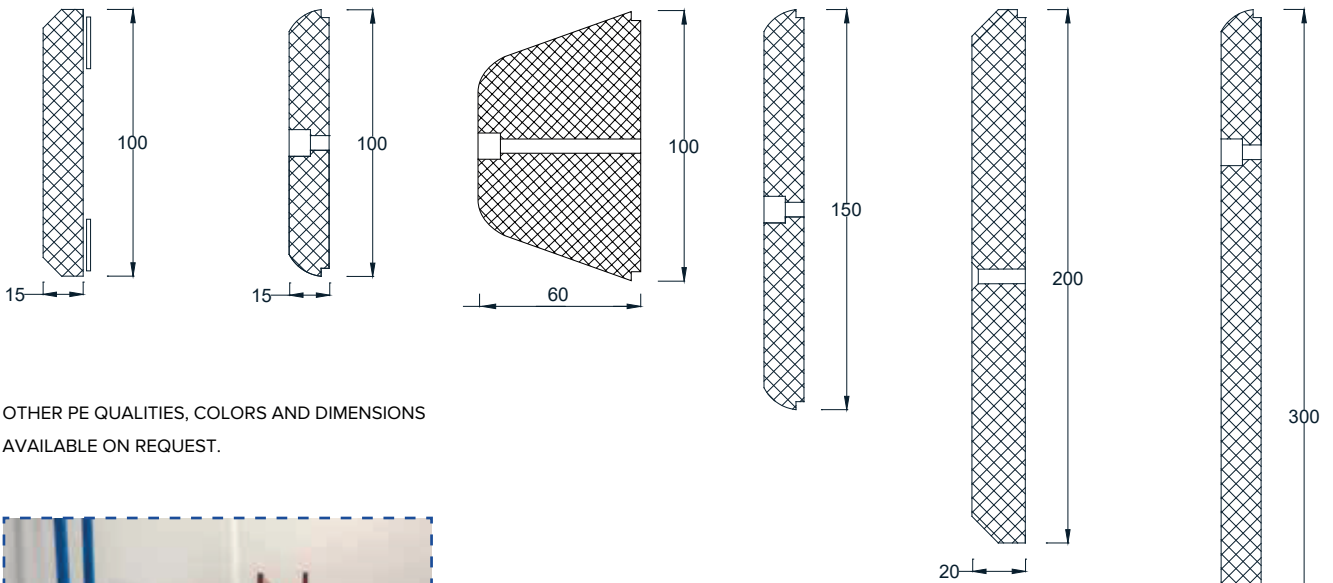

OTHER PE QUALITIES, COLORS AND DIMENSIONS AVAILABLE ON REQUEST.



PE END CAP AND STAINLESS STEEL SCREW

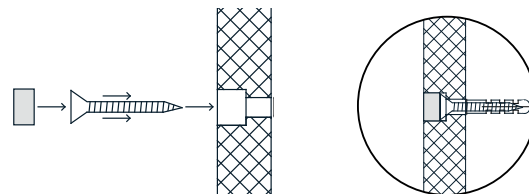

POLYSTO EXTREME IMPACT

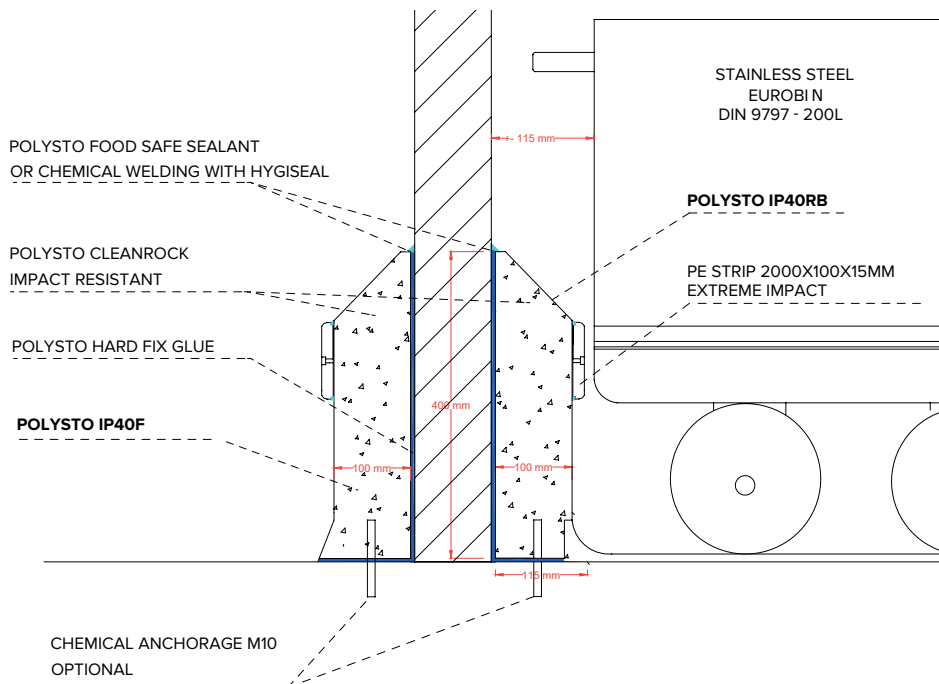

A polyethylene strip installed on a kerb is the perfect heavy impact protection for areas with high internal traffic and constant impacts.

A polyethylene strip can quickly be fitted to our PolySto kerbs using the selfadhesive tape on the back of the strip or by mechanical fix using stainless steel screws.



PolySto IP40F Natural Extreme Impact

POLYSTO STAINLESS STEEL SAFETY BOLLARDS

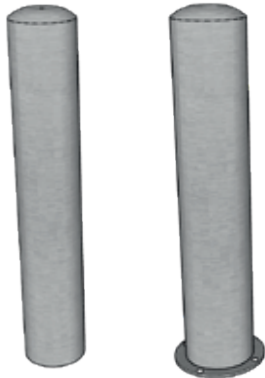

BUILT IN

FIXED ON

Protect your building, doors and other important fixtures by fitting PolySto Stainless Steel safety posts. PolySto Stainless Steel posts and barriers can be filled with concrete to provide extra protection against heavy impacts.

Quality: AISI 304L or 316L

Standard diameters:
104 mm - 154 mm - 204 mm



Finishing: Matt - gloss - brushed



PolySto built in Stainless Steel bollards.

POLYSTO STAINLESS STEEL SAFETY BARRIERS

PolySto Stainless Steel barriers provide the perfect protection for sliding doors and gates.

Quality: AISI 304L or 316L

Standard diameters:
104 mm - 154 mm - 204 mm



Other dimensions are possible!

Finishing: Matt - gloss - brushed



PolySto built in Stainless Steel bollards and barrier

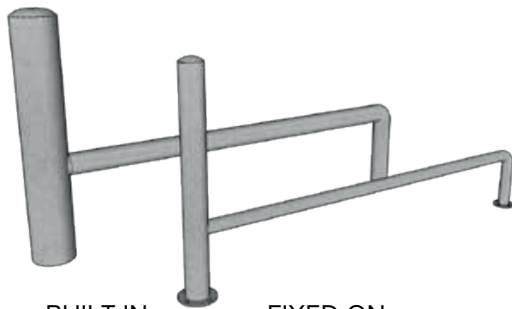

BUILT IN

FIXED ON

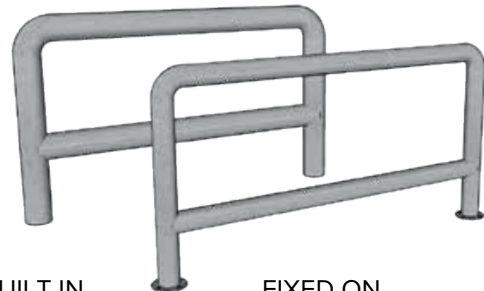

BUILT IN

FIXED ON



FILLED WITH CONCRETE



PolySto built in Stainless Steel bollards and barrier

CLEANROCK - NATURAL, SANICOAT OR STAINLESS STEEL

NATURAL

PolySto Natural kerbs are the perfect food safe kerbs, they are smooth, impact and water resistant. These kerbs are purely made of CleanRock without extra coating which makes them stronger and more economically.



SANICOAT

PolySto SaniCoat is an impact resistant, smooth gelcoat which is resistant to continuous water exposure. PolySto SaniCoat is very easy to clean with all regular food and clean room industry cleaning products.



SANICOAT

PolySto SaniCoat is an impact resistant, smooth gelcoat which is resistant to continuous water exposure. PolySto SaniCoat is very easy to clean with all regular food and clean room industry cleaning products.



INSTALLATION - MAINTENANCE - ACCESSORIES



INTERNAL CORNERS



EXTERNAL CORNERS



DOOR ENDPIECE LEFT/RIGHT

Save time and money!
Open your factory faster by using the unique quick installed PolySto prefab system.

Easy maintenance and repairs!
Complete set of products to maintain your PolySto kerbs in the future.

OP30SF SMALL
(TO BE PLACED BEHIND SLIDING DOOR)



FOOD SAFE SEALANT - HYGISEAL

PolySto Food Safe Sealant

1-component, ready to use neutral sealant with extra spectrum fungicide for a longer lifespan.
Available in white - transparent (grey) - Stainless Steel
RAL 9002



POLYSTO OP30F INSTALLED ON A CONCRETE FLOOR FINISHED WITH FOOD SAFE SEALANT

PolySto Hygiseal (chemical welding) creates a seamless transition by using a 2-component system which provides a very strong bond.

Available in white - RAL 9002 - Grey
Flexibility: 15%



POLYSTO OP30RB SANICOAT WITH EPOXY FLOOR COVING APPLIED INTO A REBATE AND FINISHED WITH POLYSTO HYGISEAL.

CleanRock[®]

CleanRock is the patented core material used in PolySto kerbs. The composition has been developed based on more than 25 years of experience in the food processing industry. Prefabricated CleanRock kerbs are composed of a mixture of polyester resins, quartz granulates and additives. The unique composition allows to prevent contaminations with Salmonella and Listeria. CleanRock is ideal for food safe environments that have to comply with HACCP, EU, USDA, GFSI (Global Food Safety Standard Initiative), BRC and other food safety standards.

CHARACTERISTICS



Time saving



Impact resistant



Water proof



Food Safe (HACCP)



Sustainable



Save money



Repairable



Chemical resistant



Prefab system



Frost resistant



All possible RAL colors



Place saving

APPLICATIONS

Meat Processing Industry - Abattoirs - Fish Processing Industry - Dairy Industry - Beverage Industry - Fruit and Vegetable Industry - Confectionary Industry - Supermarkets - Freezers - Logistics - Catering - Retail Shops - Restaurants - Pharmaceutical Industry - Hospitals - Industrial Bakeries - Cosmetics - Tobacco - Chemical Industry - Blast Freezers - Electronical industry,...



POLYSTO IP40RB NATURAL WITH EPOXY FLOOR COVING APPLIED INTO A REBATE.



POLYSTO IP40F SANICOAT INSTALLED ON AN EPOXY FLOOR.





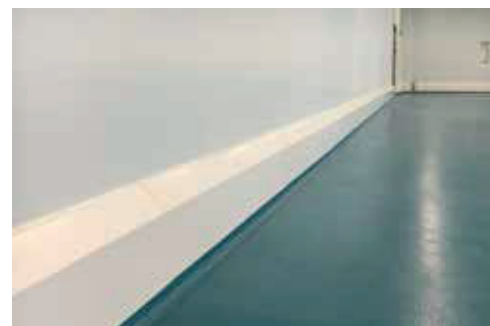

POLYSTO OP20F INOX INSTALLED ON A CONCRETE FLOOR.



POLYSTO IP40RB SANICOAT WITH EPOXY FLOOR COVING APPLIED INTO A REBATE.

EXCEPTIONAL HYGIENE

 Saudi Arabia, P.O Box 53407,
Jeddah 21583 Al Khayat Tower,
Office No. 230

 +966 12 66 333 18
 +966 12 66 332 38
 info@exceptionalco.com

 www.exceptionalco.com